

689 (DUAL SPEED)

629 (SINGLE SPEED)

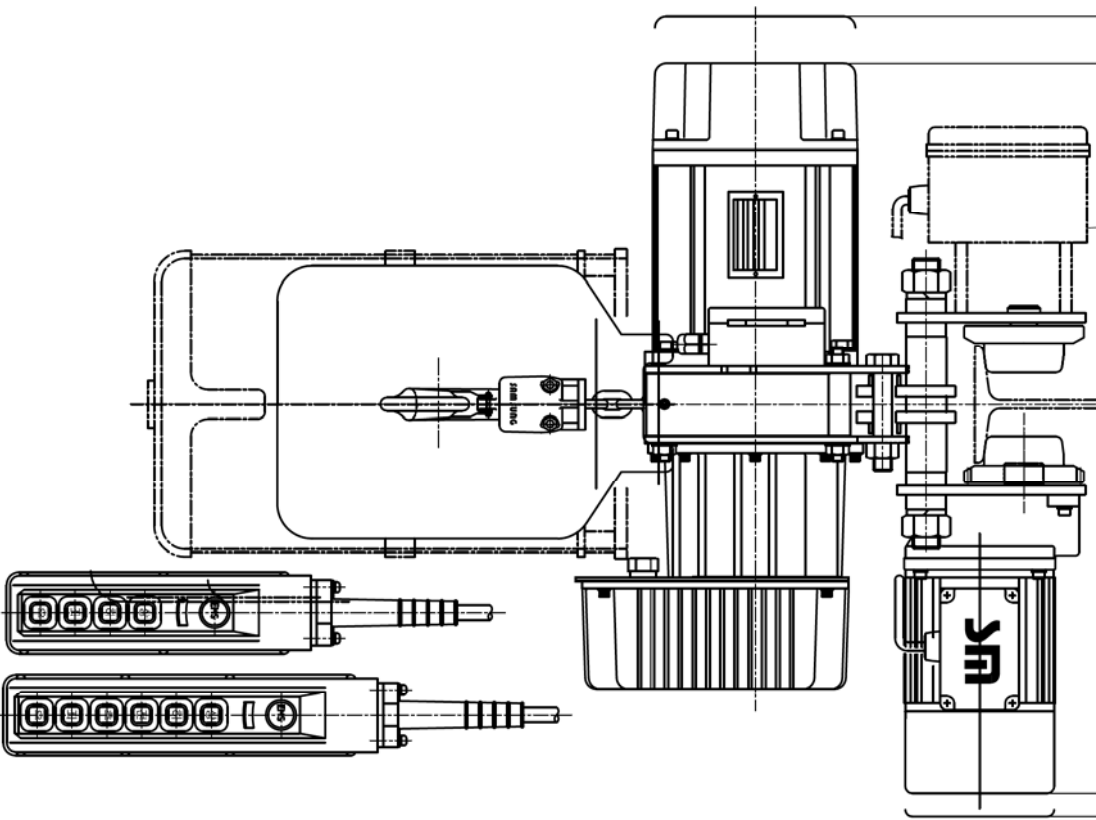

DUAL SPEED ONLY



398

139 259

457

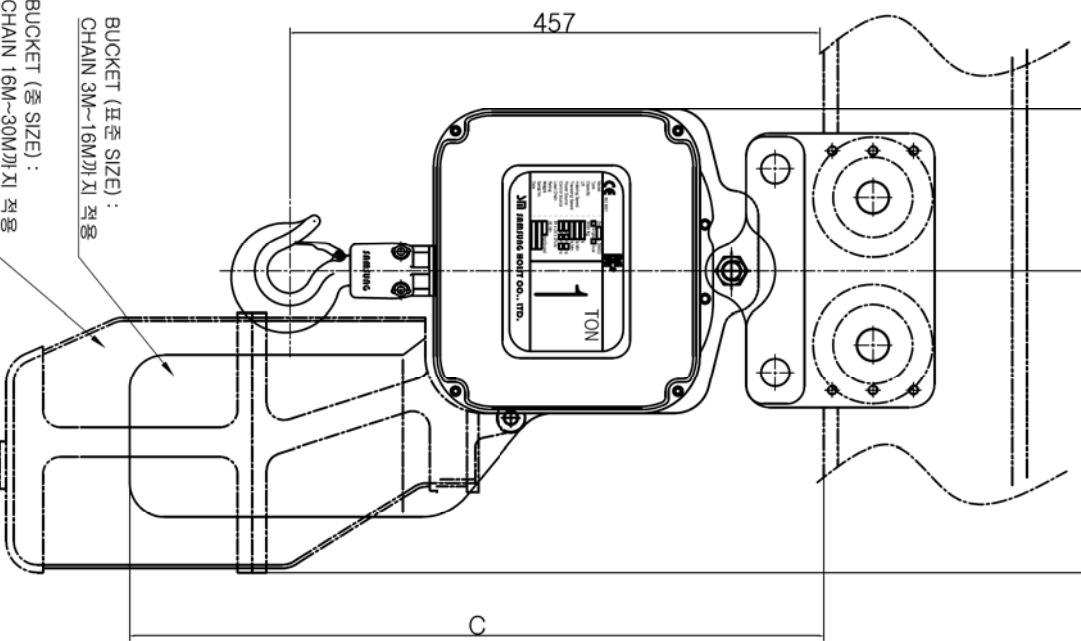

BUCKET (표준 SIZE) :
CHAIN 3M~16M까지 적용

BUCKET (중 SIZE) :
CHAIN 16M~30M까지 적용

SPECIFICATION

HOISTING LOAD	1 TON	
TESTING LOAD	1.25 TON	
LIFTING HEIGHT	Min. 30 M ~ Max 90 M	
HOISTING	SINGLE	SPEED 7.0 M/MIN MOTOR 1.5 Kw x 4 P
	DUAL	SPEED 7.0/3.5 M/MIN MOTOR 1.5/0.75 Kw x 4/8 P
TRAVERSING	FAST	SPEED 20.0 M/MIN MOTOR 0.4 Kw x 4 P
	MIDDLE	SPEED 13.3 M/MIN MOTOR 0.27 Kw x 6 P
	SLOW	SPEED 10.0 M/MIN MOTOR 0.2 Kw x 8 P
DUAL	SPEED 20.0 / 10.0 M/MIN MOTOR 0.4/0.2 Kw x 4/8 P	
POWER SUPPLY	3Ø, 220~575V, 60Hz 1Ø, 110~230V, 60Hz	
CONTROL VOLTAGE	1Ø -48V / 110V -60Hz	
OPERATING METHOD	PUSH BUTTON TYPE	
LOAD CHAIN SPEC.	Ø7.1 x 21P x 1 FALL	
WIDTH OF BEAM	100 ~ 150 mm	
RADIUS OF BEAM	MIN. 1500 mm	
RATING	30 MIN.	
NET WEIGHT	APPROX Min.84.4KG~Max.193KG	

DIMENSIONS

구분	양정 (LIFT)		
	3M~16M	16M~30M	30M~50M
기호	C	600	690
		890	

SCT-1000

TITLE OF PROJECT 1 TON MOTOR TROLLEY TYPE
ELEC. CHAIN HOIST GENERAL ASSEMBLY

NO.	DESCRIPTION	MATL.	SIZE	QTY	REMARKS
DRWING NO.	CHECKED	SCALE	DATE	DRWG. NO.	
DESIGN NO.	APPROVED	DATE	2013.05.10	SCT-1000	
DESIGNED	정영환				

REV	DATE	REASON FOR REVISION	CHECKER BY	APP'D BY
Δ				