

REV	DATE	REASON FOR REVISION	CHECKER BY	APP'D BY
△				

**SPECIFICATION**

HOISTING LOAD	1.5 TON	
TESTING LOAD	1.875 TON	
LIFTING HEIGHT	Min. 3 M ~ Max 50 M	
HOISTING	SINGLE	SPEED 8.0 M/MIN MOTOR 2.5 Kw x 4 P
	DUAL	SPEED 8.0 / 4.0 M/MIN MOTOR 2.5/1.25 Kw x 4/8 P
FAST	MOTOR	19.0 M/MIN
	SPEED	0.4 Kw x 4 P
MIDDLE	MOTOR	12.0 M/MIN
	SPEED	0.27 Kw x 6 P
SLOW	MOTOR	9.5 M/MIN
	SPEED	0.2 Kw x 8 P
DUAL	MOTOR	19 / 9.5 M/MIN
	MOTOR	0.4/0.2 Kw x 4/8 P
POWER SUPPLY	3Ø-220-575V-60Hz	
CONTROL VOLTAGE	1Ø -48, 110V -60Hz	
OPERATING METHOD	PUSH BUTTON TYPE	
LOAD CHAIN SPEC.	Ø8.0 x 24P x 1 FALL	
WIDTH OF BEAM	100~150 mm	
RADIUS OF BEAM	MIN. 1500 mm	
RATING	30 MIN.	
NET WEIGHT	APPROX Min92KG~Max.144KG	

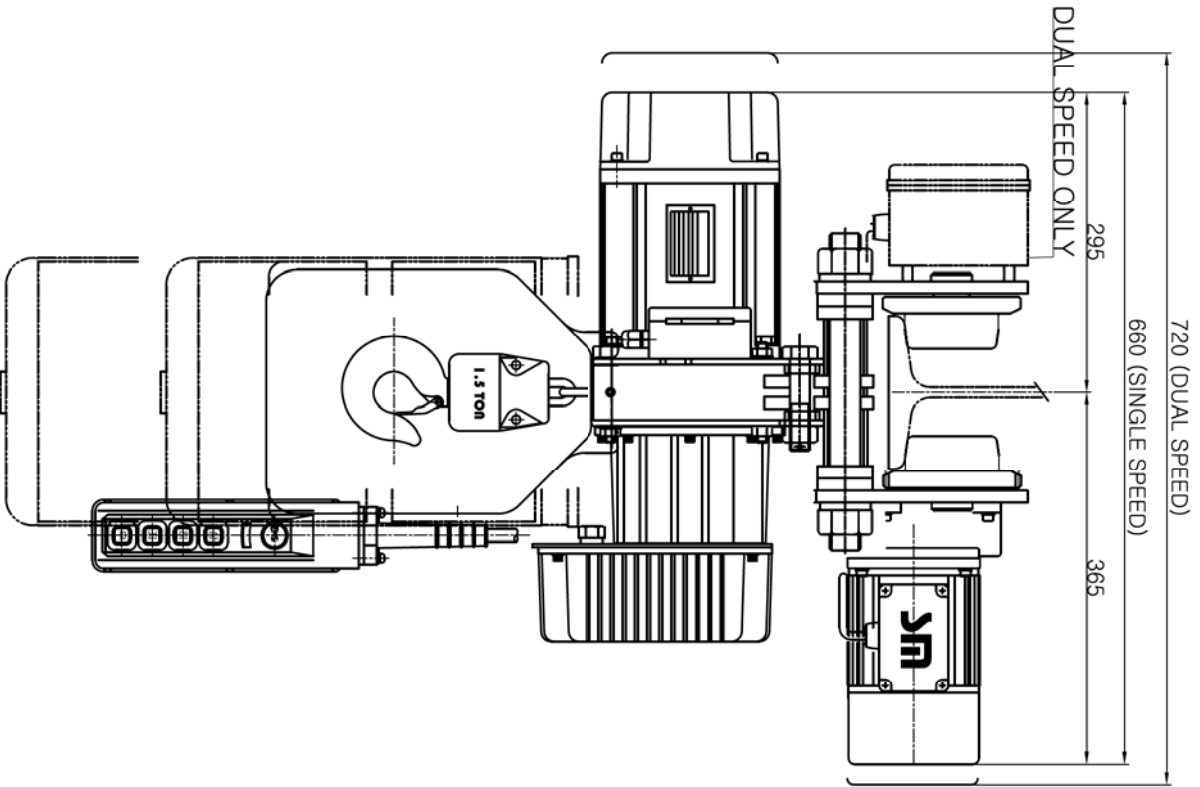
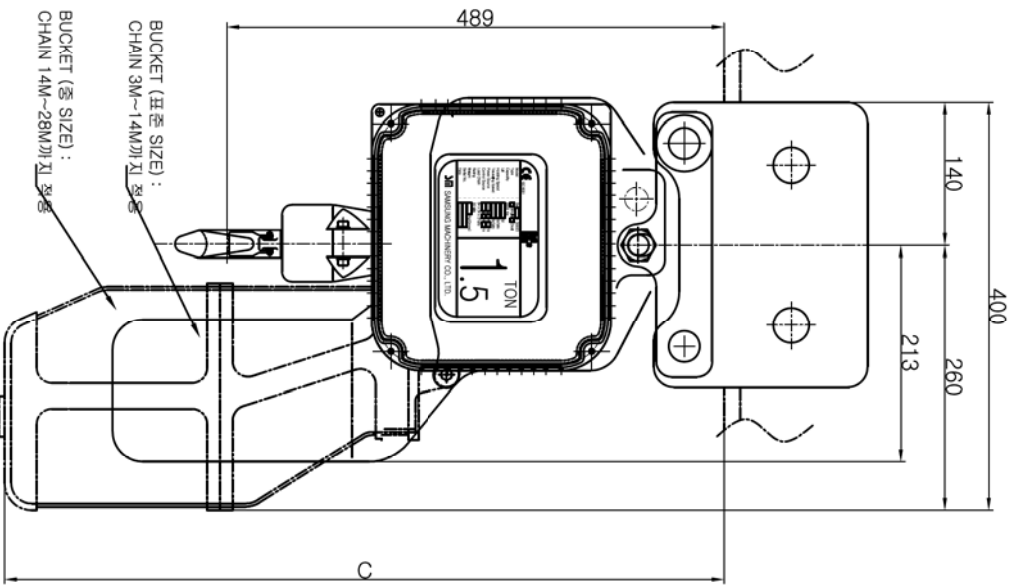

구분		양정(UP/LIFT)		
기호		3M~13M	14M~26M	26M~45M
C		620	710	910

NO	DESCRIPTION	MATL	SIZE	QTY	REMARKS
800	TROLLEY ASSY			1	
700	ELEC. ASSY			1	
600	HOIST MOTOR ASSY			1	
500	BUCKET ASSY			1	
400	BOTTOM HOOK ASSY			1	
200	GEAR BOX ASSY			1	
100	CENTER FRAME ASSY			1	

TITLE OF PROJECT  
ELEC. CHAIN HOIST GENERAL ASSEMBLY

DRAWING NO.	SCALE	DATE	APP'D BY
SC-T-1500	1/1	2013.05.10	

SC-T-1500