

593(FAST & DUAL)

573(SINGLE)

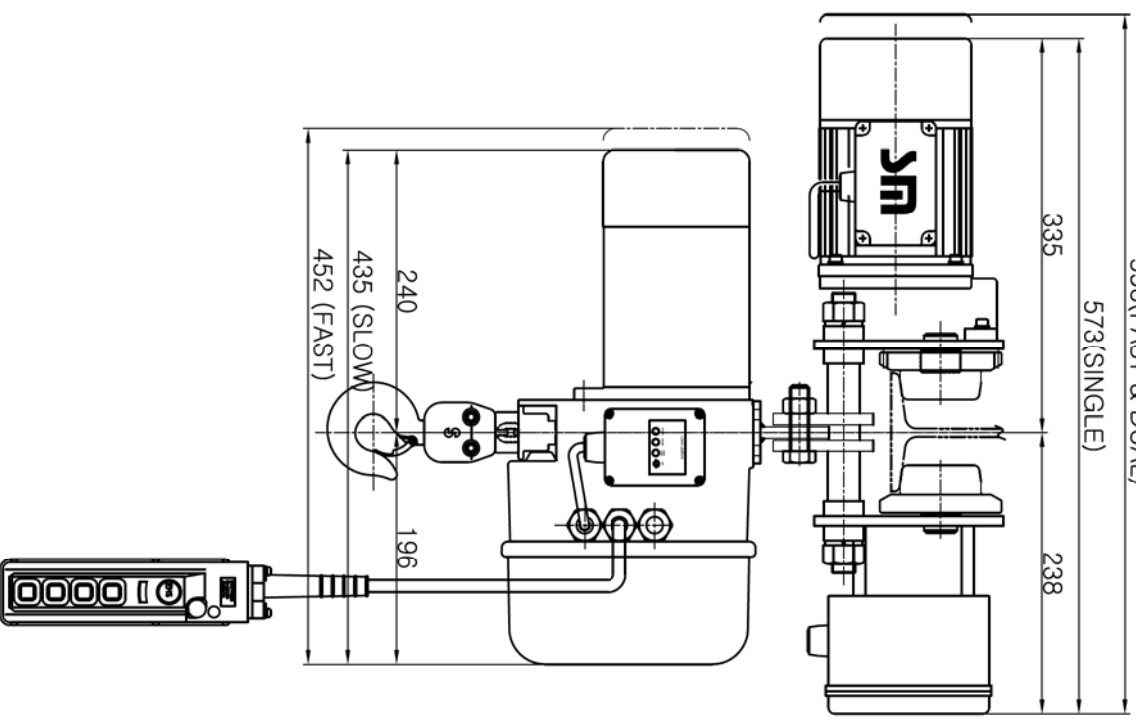

130

193

452

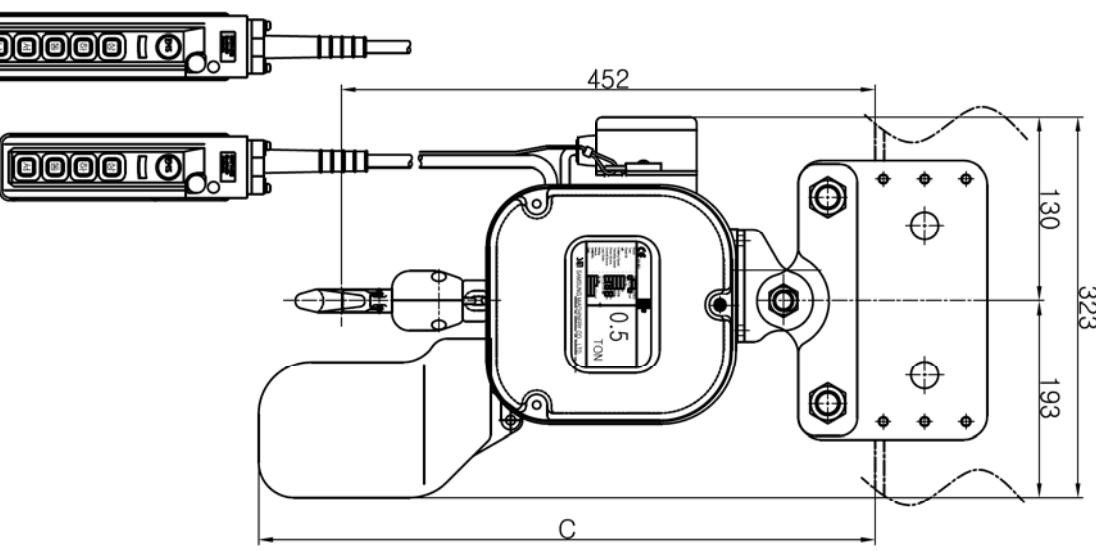

SPECIFICATION

HOISTING LOAD	0.5 TON	
TESTING LOAD	0.62 TON	
LIFTING HEIGHT	Min. 3 M ~ Max 50 M	
HOISTING	FAST	SPEED 8.4 M/MIN MOTOR 1.1 Kw x 4 P
	SLOW	SPEED 5.6 M/MIN MOTOR 0.65 Kw x 4 P
	DUAL	SPEED 5.6 / 1.8 M/MIN MOTOR 0.7 / 0.23 Kw x 4/12 P
TRAVERSING	FAST	SPEED 20.0 M/MIN MOTOR 0.4 Kw x 4 P
	MIDDLE	SPEED 13.3 M/MIN MOTOR 0.3 Kw x 6 P
	SLOW	SPEED 10.0 M/MIN MOTOR 0.2 Kw x 8 P
DUAL	SPEED 20.0 / 10.0 M/MIN	
	MOTOR 0.4/0.21Kw x 4/8 P	
POWER SUPPLY	3Ø, 220~575V, 60Hz 1Ø, 110V~230V, 60Hz	
CONTROL VOLTAGE	1Ø, 48V, 110V, 60Hz	
OPERATING METHOD	PUSH BUTTON TYPE	
LOAD CHAIN SPEC.	Ø5.0 x 15P x 1 FALL	
WIDTH OF BEAM	75~125 mm	
RADIUS OF BEAM	MIN. 1500 mm	
RATING	30 MIN.	
NET WEIGHT	Max. 101KG	

DIMENSIONS

구분	양정(LIFT)		
	3M~5M	5M~11M	11M~18M
기종	525	595	641
C	525	595	641

TITLE OF PROJECT	0.5 TON MOTOR TROLLEY TYPE				
DESIGNER	ELEC. CHAIN HOIST GENERAL ASSEMBLY				
NO.	DESCRIPTION	MATL.	SIZE	QTY	REMARKS
DESIGNED	APPROVED	SCALE	DATE	QTY	REMARKS
2013.05.10	2013.05.10	1/1			
DRAWING NO.			SCT-500		
APPROVED			SCT-500H		

SCT-500 / 500H